

# AAA650

## Cylindrical Ni-MH Battery

### @ Specification

Cross Reference: IEC-HR11/45

Nominal Voltage (V)		1.2
Dimensions	Diameter (mm)	10.5 <sup>+0</sup> / <sub>-0.5</sub>
	Height (mm)	44.5 <sup>+0</sup> / <sub>-1.0</sub>
Nominal Capacity		650mAh
Apx. Weight (g)		12.5
Internal Impedance		Less than 40mO
Cycle Life		500 cycles
Condition		Ambient Temp.
Charge	Standard (80mA)	0°C-40°C
	Fast (800mA)	10°C-40°C
Discharge		-10°C-50°C
Storage	Less than 90days	-10°C-40°C
	Less than 1 year	-10°C-30°C

### @ Dimensions

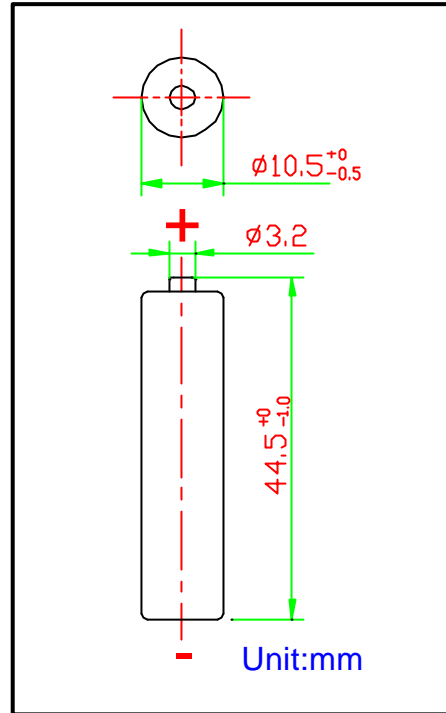

### @ Typical Charge Characteristics

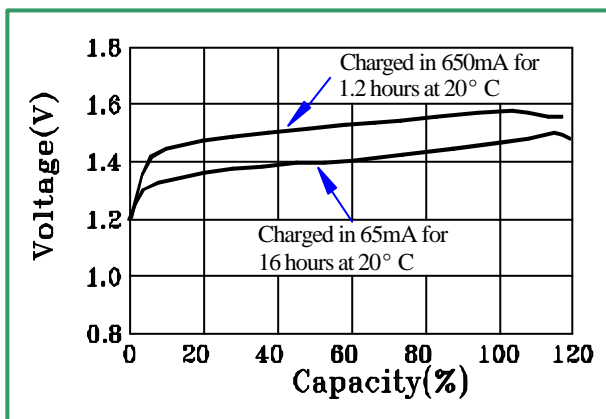

### @ Typical Discharge Characteristics

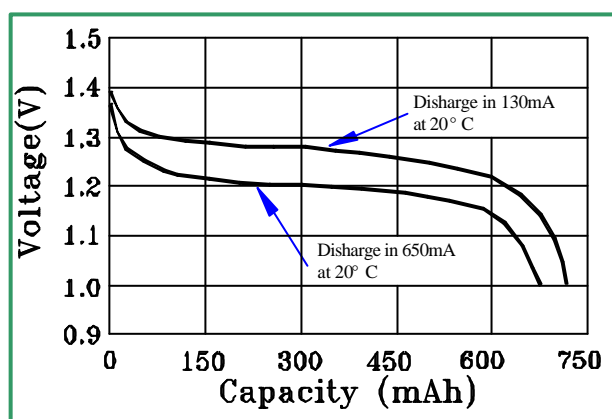

Add: No.2, Gutang'ao Industrial Area, Huizhou, Guangdong, China  
 P.C.: 516008  
 Tel: +86-752-2382997, +86-13502288850  
 Fax: +86-752-2382786  
 Website: [www.cn-battery.net](http://www.cn-battery.net)  
 E-mail: [zhou01@yeah.net](mailto:zhou01@yeah.net)

